



SY89540U

Precision Low Jitter 4x4 LVDS Crosspoint Switch with Internal Termination

General Description

The SY89540U is a low-jitter, low skew, high-speed 4x4 crosspoint switch optimized for precision telecom and enterprise server/storage distribution applications. The SY89540U guarantees data-rates up to 3.2Gbps over temperature and voltage.

The SY89540U differential input includes Micrel's unique, 3-pin input termination architecture that directly interfaces to any differential signal (AC or DC-coupled) as small as 100mV (200mV_{pp}) without any level shifting or termination resistor networks in the signal path. The LVDS compatible outputs maintain extremely fast rise/fall times guaranteed to be less than 120ps.

The SY89540U features a patent-pending isolation design that significantly improves on channel-to-channel crosstalk performance.

The SY89540U operates from a 2.5V ±5% supply and is guaranteed over the full industrial temperature range (-40°C to +85°C). The SY89540U is part of Micrel's high-speed, Precision Edge® product line.

All support documentation can be found on Micrel's web site at www.micrel.com.

Typical Performance

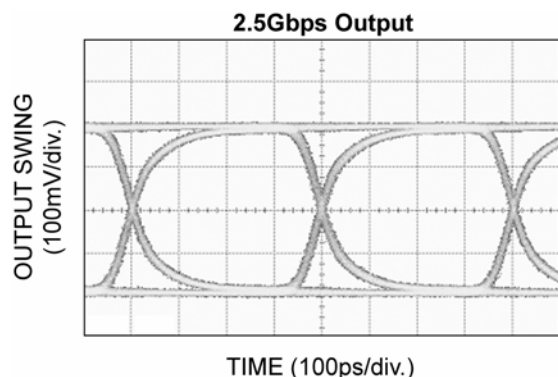

Precision Edge is a registered trademark of Micrel, Inc.
MicroLeadFrame and MLF are trademarks of Amkor Technology, Inc.



Precision Edge®

Features

- Provides crosspoint switching between any input pairs to any output pair
- Patent pending, channel-to-channel isolation design provides superior crosstalk performance
- Guaranteed AC performance over temperature and voltage:
- DC-to-3.2Gbps throughput
 - <480ps propagation delay
 - <120ps rise/fall time
 - <30ps output-to-output skew
- Ultra-low jitter design:
 - <1ps_{RMS} random jitter
 - <10ps_{PP} deterministic jitter
 - <10ps_{PP} total jitter (clock)
 - <0.7ps_{RMS} crosstalk induced jitter
- Patent pending 50Ω input termination, extended CMVR, and VT pin accepts DC- and AC-coupled differential inputs
- 350mV LVDS output swing
- Power supply 2.5V ±5%
- -40°C to +85°C temperature range
- Available in 44-pin (7mm x 7mm) MLF™ package
- Pb-Free Green package

Applications

- All SONET/SDH channel select applications
- All Fibre Channel multi-channel select applications
- All Gigabit Ethernet multi-channel select applications

Functional Block Diagram

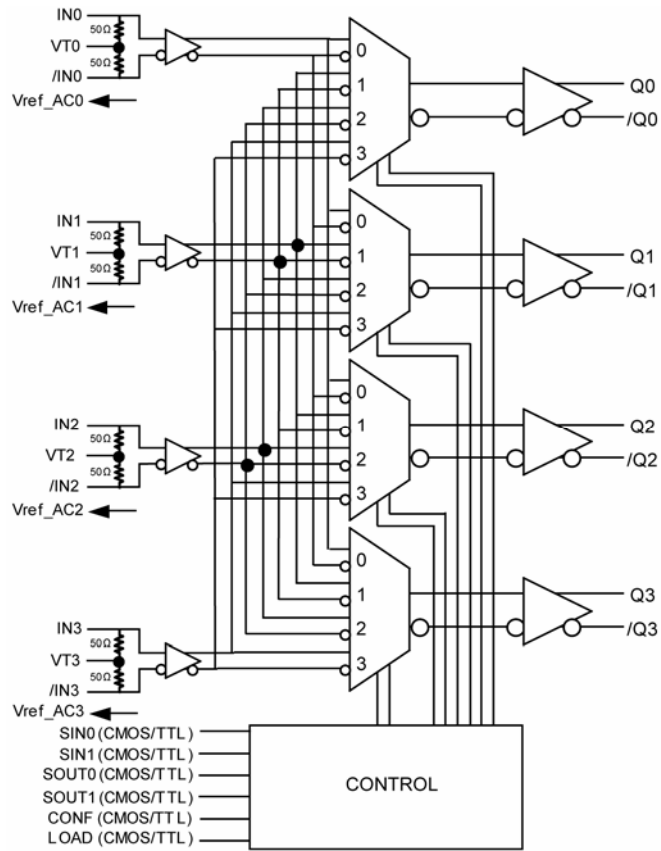

Ordering Information⁽¹⁾

Part Number	Package Type	Temperature Range	Package Marking	Lead Finish
SY89540UMI	MLF-44	Industrial	89540U	Sn-Pb
SY89540UMITR ⁽²⁾	MLF-44	Industrial	89540U	Sn-Pb
SY89540UMG	MLF-44	Industrial	89540U with Pb-Free bar-line indicator	Pb-Free NiPdAu
SY89540UMGTR ⁽²⁾	MLF-44	Industrial	89540U with Pb-Free bar-line indicator	Pb-Free NiPdAu

Notes:

1. Contact factory for die availability. Dice are guaranteed at T_A = 25°C, DC electrical only.
2. Tape and Reel ordering option.

Pin Configuration

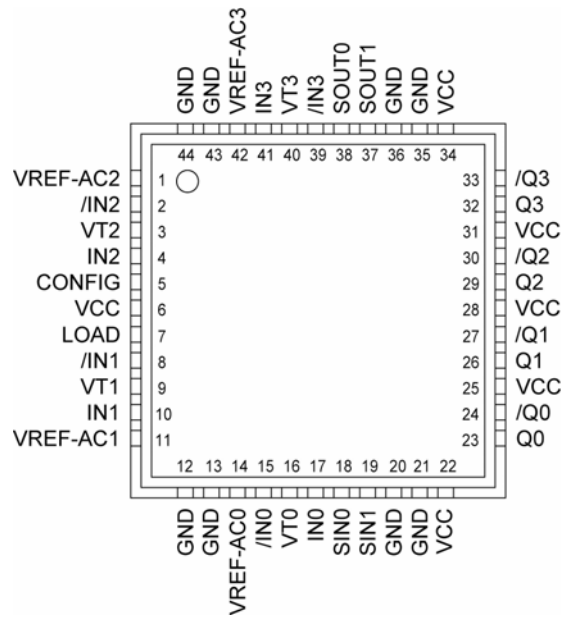

44-Pin MLF™ (MLF-44)

Pin Description

Pin Number	Pin Name	Pin Function
17, 15, 10, 8 4, 2 41, 39	IN0, /IN0, IN1, /IN1, IN2, /IN2, IN3, /IN3	Differential Inputs: These input pairs are the differential signal inputs to the device. Inputs accept AC- or DC-coupled signals as small as 100mV. Each pin of a pair internally terminates to a VT pin through 50Ω. Note that these inputs will default to an indeterminate state if left open. Please refer to the "Input Interface Applications" section for more details.
16, 9, 3, 40	VT0, VT1, VT2, VT3	Input Termination Center-Tap: Each side of the differential input pair terminates to a VT pin. The VT pins provide a center-tap to a termination network for maximum interface flexibility. See "Input Interface Applications" section for more details.
14, 11, 1, 42	VREF_AC0, VREF_AC1, VREF_AC2, VREF_AC3	Reference Voltage: This output biases to $V_{CC}-1.2V$. It is used when AC-coupling the inputs (IN, /IN). Connect VREF_AC to the VT pin. Bypass each VREF-AC pin with a 0.01μF low ESR capacitor. See "Input Interface Applications" section for more details.
18, 19	SIN0, SIN1	These single-ended TTL/CMOS-compatible inputs address the data inputs. Note that these inputs are internally connected to a 25kΩ pull-up resistor and will default to a logic HIGH state if left open.
38, 37	SOUT0, SOUT1	These single-ended TTL/CMOS-compatible inputs address the data outputs. Note that these inputs are internally connected to a 25kΩ pull-up resistor and will default to logic HIGH state if left open.
5, 7	CONF, LOAD	<p>These single-ended TTL/CMOS-compatible inputs control the transfer of the addresses to the internal multiplexers. See "Address Tables" and "Timing Diagram" sections for more details. Note that these inputs are internally connected to a 25kΩ pull-up resistor and will default to logic HIGH state if left open.</p> <p><i>Configuration Sequence</i></p> <ol style="list-style-type: none"> 1. Load: Loads configuration into buffer, while Configuration Buffer holds existing switch configuration. 2. Configuration: Loads new configuration into the Configuration Buffer and updates switch configuration. <p><i>Buffer Mode</i></p> <p>The SY89540U defaults to buffer mode (IN to Q) if the load and configuration control signals are not exercised.</p>
23, 24, 26, 27, 29, 30, 32, 33	Q0, /Q0, Q1, /Q1, Q2, /Q2, Q3, /Q3,	Differential Outputs: These LVDS output pairs are the outputs of the device. Please refer to the truth table below for details. Unused output pairs may be left open. Each output is designed to drive 350mV into 100Ω across the pair.
6, 22, 25, 28, 31, 34	VCC	Positive power supply. Bypass with 0.1μF//0.01μF low ESR capacitors and place as close to each V_{CC} pin.
12, 13, 20, 21,35, 36, 43, 44	GND, Exposed pad	Ground. GND and EPad must both be connected to the same ground.

Functional Description

Buffer Mode

SY89540 can be used as a 1:4 fanout buffer. This is the default mode with LOAD and CONFIG being HIGH when the device is first powered up. The SIN0 and SIN1 inputs select the input signal that will be buffered. Regardless of the output switch selection, the input signal will be buffered to all four outputs.

Crosspoint Mode

SY89540 can be programmed to take differential input signals from any input and buffer the signals to one or more outputs. Prior to configuring SIN and SOUT, LOAD and CONFIG must be LOW. To program the desired I/O combination, follow the following sequence:

- 1) Select the desired input with the SIN0 and SIN1 inputs and the output with the SOUT0 and SOUT1.
- 2) Pulse the LOAD with a positive pulse to load SIN and SOUT.
- 3) Pulse the CONFIG pin with a positive pulse to latch the I/O configuration.
- 4) This method can be used to create independent paths between inputs and outputs. Below is the truth table to create a 4:4 buffer where IN0 -> Q3, IN1 -> Q2, IN2 -> Q1, and IN3 -> Q0:

The SY89540 can be switched from crosspoint mode to a 1:4 fanout buffer simply by providing a LOW-to-HIGH pulse to the LOAD and CONFIG pins. The input configuration (SIN0:1) will select the desired input signal while the output switch will buffer the selected input signal. To get the same desired input to all four outputs (1:4), LOAD and CONFIG must be repeated four times to cover all outputs (i.e., SOUT0:1 must go through all four output combinations, repeated by LOAD and CONFIG).









Input	SIN1	SIN0	SOUT1	SOUT0	Load	Config.	Output
IN0	0	0	1	1		0	Q3
					0		
IN1	0	1	1	0		0	Q2
					0		
IN2	1	0	0	1		0	Q1
					0		
IN3	1	1	0	0		0	Q0
					0		

Table 1. 4:4 Buffer Truth Table

Absolute Maximum Ratings⁽¹⁾

Supply Voltage (V_{CC}) -0.5V to +4.0V
 Input Voltage (V_{IN}) -0.5V to V_{CC}
 CML Output Voltage (V_{OUT}) $V_{CC}-1.0V$ to $V_{CC}+5.0V$
 Termination Current⁽³⁾
 Source or sink current on V_T $\pm 100mA$
 Input Current
 Source or sink current on IN, /IN $\pm 50mA$
 V_{REF-AC} Current
 Source or sink current on V_{REF-AC} $\pm 2mA$
 Lead Temperature (soldering, 20sec.) 260°C
 Storage Temperature (T_s) -65°C to +150°C

Operating Ratings⁽²⁾

Supply Voltage (V_{CC}) +2.375V to +2.625V
 Ambient Temperature (T_A) -40°C to +85°C
 Package Thermal Resistance⁽⁴⁾
 MLF[®] (θ_{JA})
 Still-air 23°C/W
 MLF[®] (ψ_{JB})
 Junction-to-board 12°C/W

DC Electrical Characteristics⁽⁵⁾

$T_A = -40^\circ C$ to $+85^\circ C$, unless otherwise noted.

Symbol	Parameter	Condition	Min	Typ	Max	Units
V_{CC}	Power Supply	$V_{CC} = 2.5V$	2.375	2.5	2.625	V
I_{CC}	Power Supply Current	No load, max. V_{CC} .		200	280	mA
R_{DIFF_IN}	Differential Input Resistance (IN-to-/IN)		80	100	120	Ω
R_{IN}	Input Resistance (IN-to- V_T , /IN-to- V_T)		40	50	60	Ω
V_{IH}	Input HIGH Voltage (IN, /IN)		1.2		V_{CC}	V
V_{IL}	Input LOW Voltage (IN, /IN)		0		$V_{IH}-0.1$	V
V_{IN}	Input Voltage Swing (IN, /IN)	See Figure 1a.	0.1		1.7	V
V_{DIFF_IN}	Differential Input Voltage IN, /IN	See Figure 1b.	0.2			V
IN-to- V_T	Maximum Input Voltage IN-to- V_T				1.28	V
V_{REF-AC}	Reference Voltage		$V_{CC}-1.3$	$V_{CC}-1.2$	$V_{CC}-1.1$	V

Notes:

1. Permanent device damage may occur if ratings in the “Absolute Maximum Ratings” section are exceeded. This is a stress rating only and functional operation is not implied for conditions other than those detailed in the operational sections of this data sheet. Exposure to absolute maximum ratings conditions for extended periods may affect device reliability.
2. The data sheet limits are not guaranteed if the device is operated beyond the operating ratings.
3. Due to limited drive capability use for input of the same package only.
4. Assumes exposed pad is soldered (or equivalent) to the device’s most negative potential on the PCB. ψ_{JB} uses a 4-layer θ_{JA} in still-air unless otherwise stated.
5. The circuit is designed to meet the DC specifications shown in the above table after thermal equilibrium has been established.

LVDS Outputs DC Electrical Characteristics

$V_{CC} = 2.5V \pm 5\%$, $T_A = -40^\circ C$ to $+85^\circ C$, $R_L = 100\Omega$ across Q and /Q, unless otherwise noted.

Symbol	Parameter	Condition	Min	Typ	Max	Units
V_{OH}	Output HIGH Voltage (Q, /Q)				1.475	V
V_{OL}	Output LOW Voltage (Q, /Q)		0.925			V
V_{OUT}	Output Voltage Swing (Q, /Q)	See Figure 1a.	250	350		mV
V_{DIFF_OUT}	Differential Output Voltage Swing Q - /Q	See Figure 1b.	500	700		mV
V_{OCM}	Output Common Mode Voltage (Q, /Q)	See Figure 4b.	1.125		1.275	V
ΔV_{OCM}	Change in Common Mode Voltage (Q, /Q)	See Figure 4b.	-50		+50	mV

LVTTL/CMOS DC Electrical Characteristics

$V_{CC} = 2.5V \pm 5\%$, $T_A = -40^\circ C$ to $+85^\circ C$, unless otherwise noted.

Symbol	Parameter	Condition	Min	Typ	Max	Units
V_{IH}	Input HIGH Voltage		2.0		V_{CC}	V
V_{IL}	Input LOW Voltage				0.8	V
I_{IH}	Input HIGH Current		-125		30	μA
I_{IL}	Input LOW Current	$V_{IL} = 0V$	-300			μA

AC Electrical Characteristics⁽⁷⁾

$V_{CC} = 2.5V \pm 5\%$, $T_A = -40^\circ C$ to $+85^\circ C$, $R_L = 100\Omega$ across each output pair, unless otherwise noted.

Symbol	Parameter	Condition	Min	Typ	Max	Units
f_{MAX}	Maximum Operating Frequency	NRZ Data	3.2	4		Gbps
t_{PD}	Propagation Delay	Clock, $V_{OUT} \geq 200mV$		4		GHz
		IN-to-Q	280	380	480	Ω
		CONFIG-to-Q	350		800	
t_{PD} Tempco			160			fs/ $^\circ C$
t_S	Set-up Time SIN-to-LOAD SOUT-to-LOAD LOAD-to-CONFIG CONFIG-to-LOAD		800			ps
			800			
			800			
			950			
t_H	Hold Time LOAD-to-SIN, LOAD-to-SOUT		800			ps
t_{PW}	Minimum LOAD and CONFIG Pulse Width		800			ps
t_{SKEW}	Output-to-Output Skew Part-to-Part Skew	Note 8			30	ps
		Note 9			150	ps
t_{JITTER}	Data Random Jitter (RJ) Deterministic Jitter (DJ)	Note 10 Note 11			1 10	μS_{RMS} μS_{PP}
	Clock Cycle-to-Cycle Jitter Total Jitter (TJ)	Note 12 Note 13			1	μS_{RMS} μS_{PP}
	Crosstalk-Induced Jitter	Note 14			0.7	μS_{RMS}
t_r, t_f	Rise/Fall Times	At full output swing (20% to 80%)	40	80	120	ps

Notes:

- High frequency AC-parameters are guaranteed by design and characterization.
- Output to output skew is measured between two different outputs under identical transitions. Input voltage swing is $\geq 100mV$.
- Part-to-part skew is defined for two parts with identical power supply voltages at the same temperature and with no skew of the edges at the respective inputs.
- RJ is measured with a K28.7 comma detect character pattern, measured at 2.5Gbps/3.2Gbps.
- DJ is measured at 2.5Gbps/3.2Gbps, with both K28.5 and $2^{23}-1$ PRBS pattern
- Cycle-to-cycle jitter definition: The variation of periods between adjacent cycles, $T_n - T_{n-1}$ where T is the time between rising edges of the output signal.
- TJ definition: with an ideal clock input of frequency $\leq f_{MAX}$, no more than one output edge in 10^{12} output edges will deviate by more than the specified peak-to-peak jitter value.
- Crosstalk induced jitter is defined as the added jitter that results from signals applied to two adjacent channels. It is measured at the output while applying two similar, differential clock frequencies that are asynchronous with respect to each other at the inputs.

Single-Ended and Differential Swing



Figure 1a. Single-Ended Voltage Swing

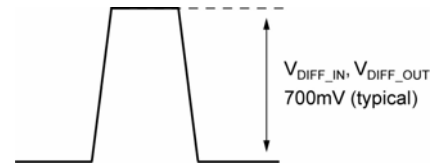
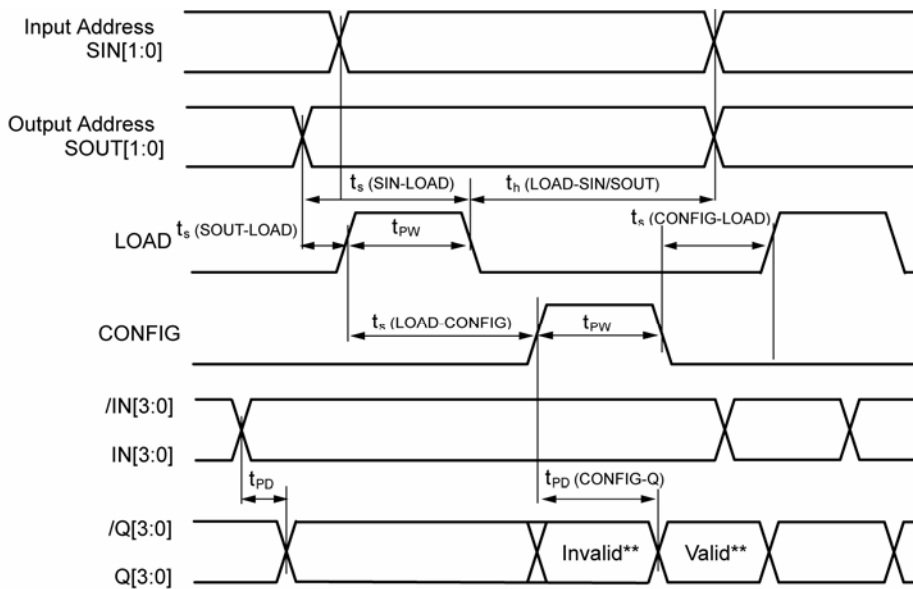

Figure 1b. Differential Voltage Swing

Timing Diagram



**Invalid and Valid refers to configuration being changed. All outputs with unchanged configuration remain valid.

Figure 2. Timing Diagram

Truth Tables

Input Select Address Table		
SIN1	SIN0	Input
0	0	IN0
0	1	IN1
1	0	IN2
1	1	IN3

Output Select Address Table		
SOUT1	SOUT0	Output
0	0	Q0
0	1	Q1
1	0	Q2
1	1	Q3

Typical Operating Characteristics

$V_{CC} = 2.5$, $V_{IN} = 100\text{mV}$, at 25°C .

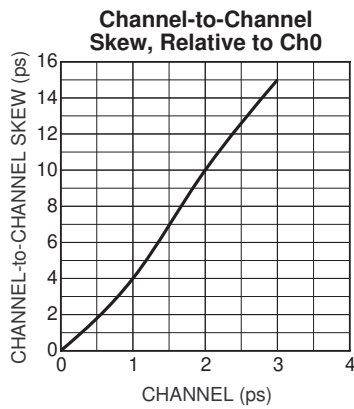
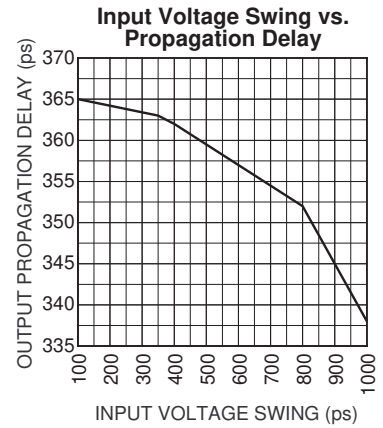
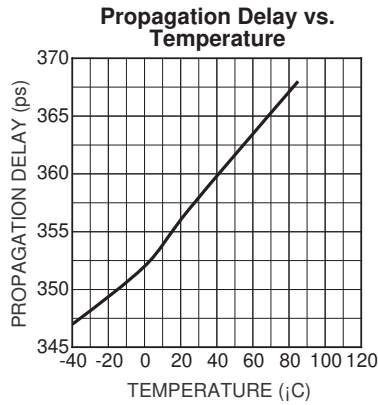
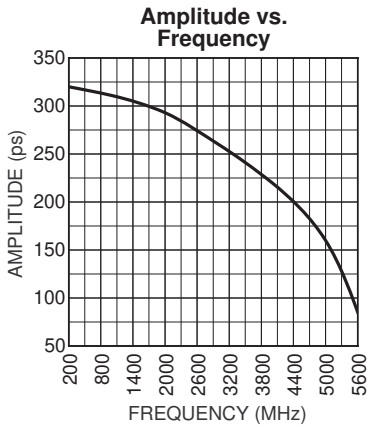

Functional Characteristics

$V_{CC} = 2.5$, $V_{IN} = 100\text{mV}$, at 25°C .

Clock Pattern

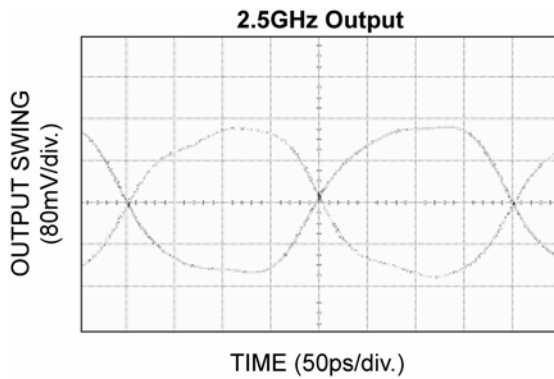
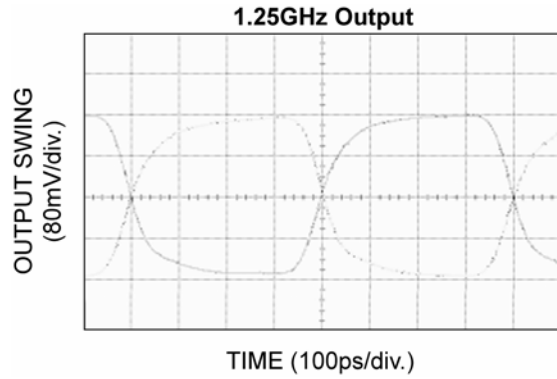
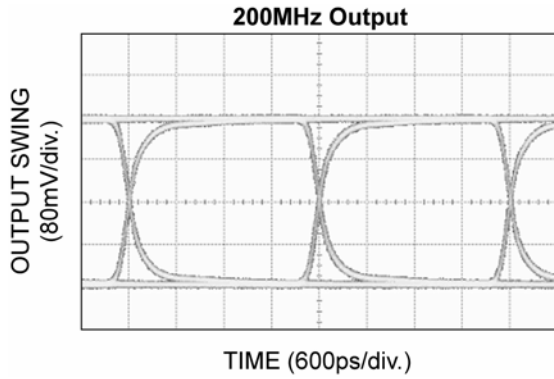

Data Pattern

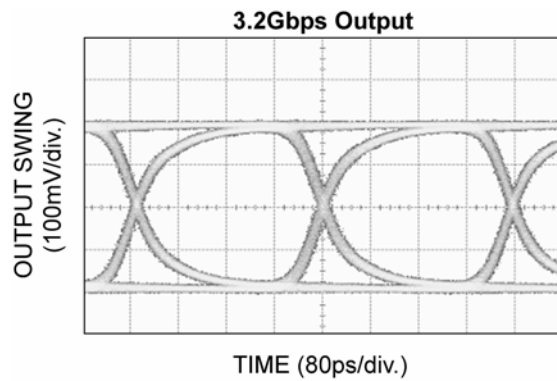
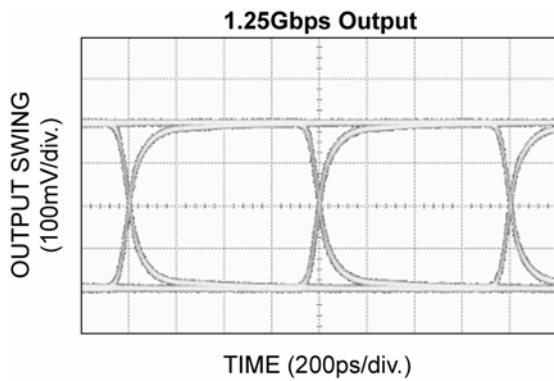

Input and Output Stage Internal Termination

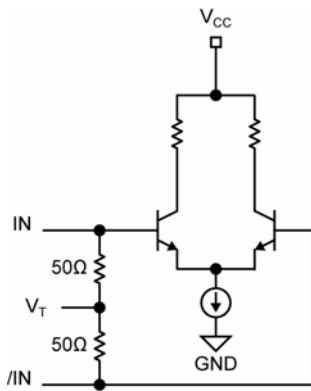

Figure 3. Simplified Differential Input Stage

Output Stage Internal Termination

On a nominal 1.25V common mode above ground, LVDS specifies a small swing of 350mV, typical. The common mode voltage has tight limits to permit large variations in ground between an LVDS driver and receiver. Also, change in common mode voltage, as a function of data input, is kept to a minimum to keep EMI low.

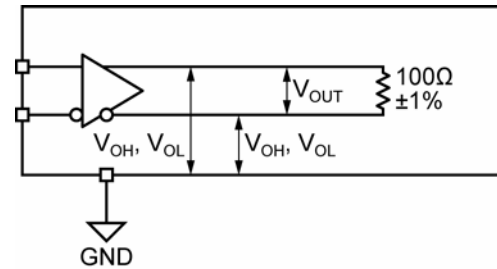

Figure 4a. LVDS Differential Measurement

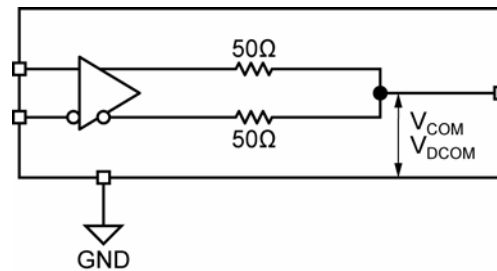

Figure 4b. LVDS Common Mode Measurement

Input Interface Applications

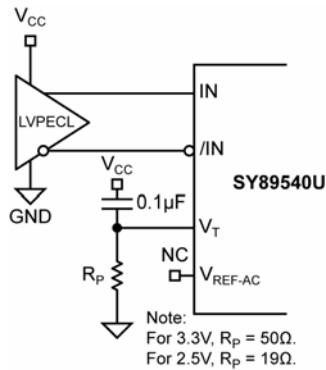

Figure 5a. LVPECL Interface (DC-Coupled)

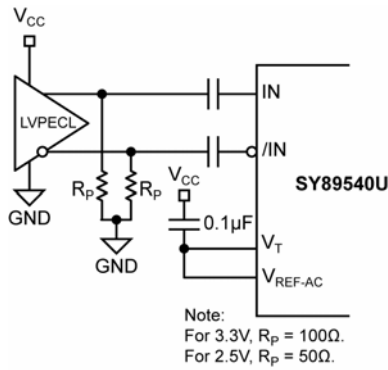

Figure 5b. LVPECL Interface (AC-Coupled)

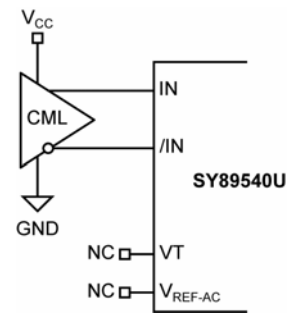

Figure 5c. CML Interface (DC-Coupled)

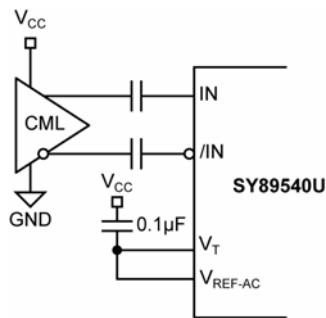

Figure 5d. CML Interface (AC-Coupled)

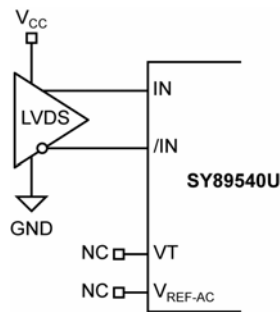
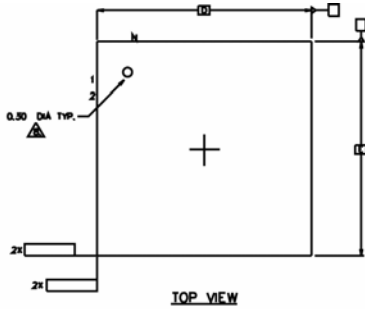

Figure 5e. LVDS Interface

Related Product and Support Documentation

Part Number	Function	Data Sheet Link
SY58540U	Ultra Precision 4x4 CML Crosspoint Switch w/Internal I/O Termination	http://www.micrel.com/product-info/products/sy89540u.shtml
HBW Solutions	New Products and Applications	www.micrel.com/product-info/products/solutions.shtml
	MLF™ Application Note	www.amkor.com/products/notes_papers/MLF_AppNote.pdf

Package Information



NOTES :

1. DIMENSIONING AND TOLERANCING CONFORM TO ASME Y14.5M. - 1994.
2. ALL DIMENSIONS ARE IN MILLIMETERS, 0 IS IN DEGREES.
3. N IS THE TOTAL NUMBER OF TERMINALS.
- △ DIMENSION b APPLIES TO METALLIZED TERMINAL AND IS MEASURED BETWEEN 0.15 AND 0.30mm FROM TERMINAL TIP. IF THE TERMINAL HAS THE OPTIONAL RADIUS ON THE OTHER END OF THE TERMINAL, THE DIMENSION b SHOULD NOT BE MEASURED IN THAT RADIUS AREA.
- △ ND AND NE REFER TO THE NUMBER OF TERMINALS ON EACH D AND E SIDE RESPECTIVELY.
6. MAX. PACKAGE WARPAGE IS 0.05 mm.
7. MAXIMUM ALLOWABLE BURRS IS 0.076 mm IN ALL DIRECTIONS.
- △ PIN #1 ID ON TOP WILL BE LASER MARKED.
- △ BILATERAL COPLANARITY ZONE APPLIES TO THE EXPOSED HEAT SINK SLUG AS WELL AS THE TERMINALS.
10. THIS DRAWING CONFORMES TO JEDEC REGISTERED OUTLINE MO-220

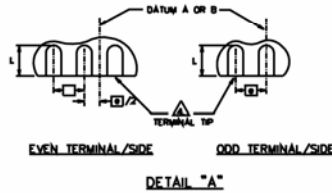
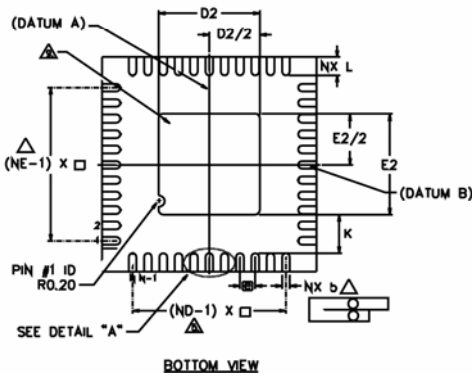
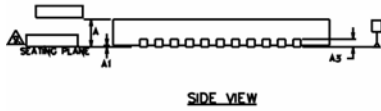

SYMBOL	DIMENSIONS			No. of
	MIN.	NOM.	MAX.	
□	0.50 BSC			
N	44			3
ND	11			△
NE	11			
L	0.55	0.60	0.65	
b	0.18	0.25	0.30	△
D2	3.20	3.30	3.40	
E2	3.20	3.30	3.40	
D	7.00 BSC			
E	7.00 BSC			
A	0.80	0.85	1.00	
A1	0.00	0.02	0.05	
K	0.20 MIN.			
θ	0	—	12	2

44-Pin MLF™ (MLF-44)

MICREL, INC. 2180 FORTUNE DRIVE SAN JOSE, CA 95131 USA
 TEL +1 (408) 944-0800 FAX +1 (408) 474-1000 WEB <http://www.micrel.com>

The information furnished by Micrel in this data sheet is believed to be accurate and reliable. However, no responsibility is assumed by Micrel for its use. Micrel reserves the right to change circuitry and specifications at any time without notification to the customer.

Micrel Products are not designed or authorized for use as components in life support appliances, devices or systems where malfunction of a product can reasonably be expected to result in personal injury. Life support devices or systems are devices or systems that (a) are intended for surgical implant into the body or (b) support or sustain life, and whose failure to perform can be reasonably expected to result in a significant injury to the user. A Purchaser's use or sale of Micrel Products for use in life support appliances, devices or systems is a Purchaser's own risk and Purchaser agrees to fully indemnify Micrel for any damages resulting from such use or sale.

© 2005 Micrel, Incorporated.